

CAME UNITED KINGDOM LTD
ORCHARD PARK INDUSTRIAL ESTATE
TOWN STREET, SANDIACRE,
NOTTINGHAM, NG10 5BP

TEL: 0115 921 0430
FAX: 0115 921 0431

INTERNET - www.cameuk.com
E-MAIL - enquiries@cameuk.com

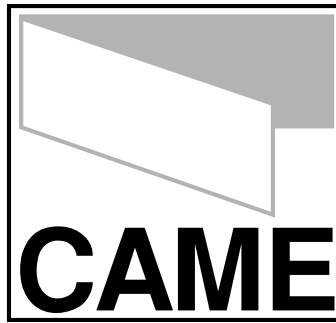

**TECHNICAL
HELPLINE
0115 921 0430**

ATI KIT

*Installation Instructions
for a "Single" gate...*

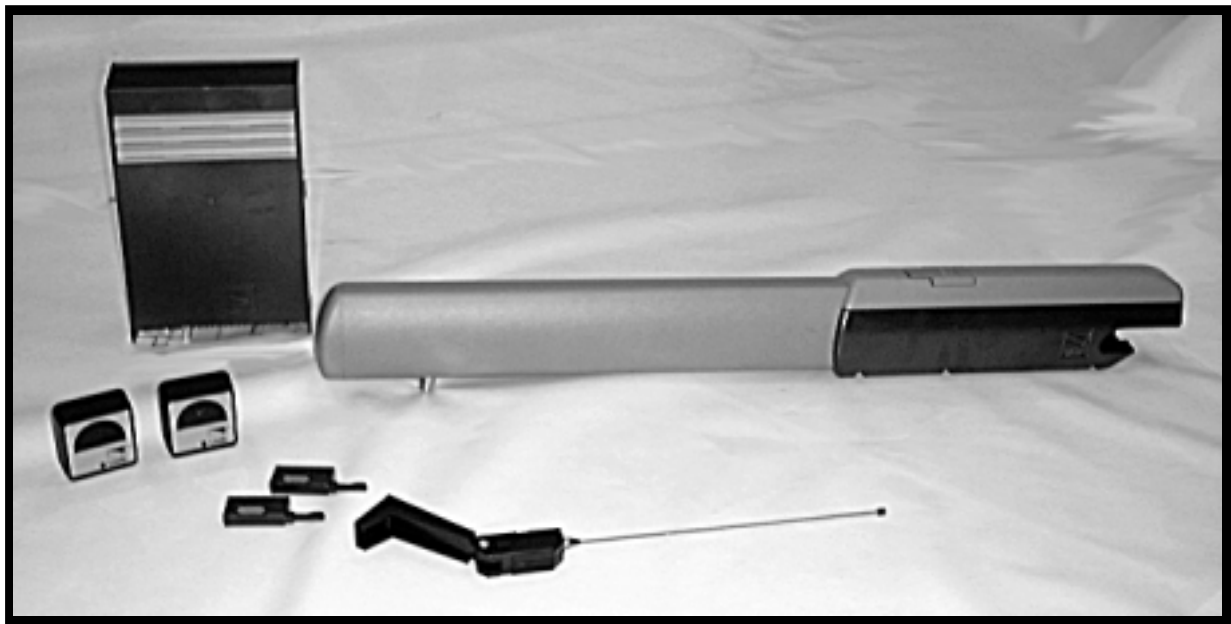

THE ATI-S KIT CONSISTS OF:

- 1 X ATI MOTOR***
- 1 X CONTROL PANEL***
- 1 X RADIO FREQUENCY CARD***
- 1 X TUNED ANTENNA***
- 2 X REMOTE CONTROL TRANSMITTERS***
- 1 X PAIR SAFETY BEAMS***

INTRODUCTION

THESE INSTRUCTIONS WILL SHOW YOU HOW TO INSTALL AN ATI MOTOR TO A SINGLE GATE.

PLEASE READ THESE INSTRUCTIONS AND DIAGRAMS CAREFULLY BEFORE STARTING ANY WORK.

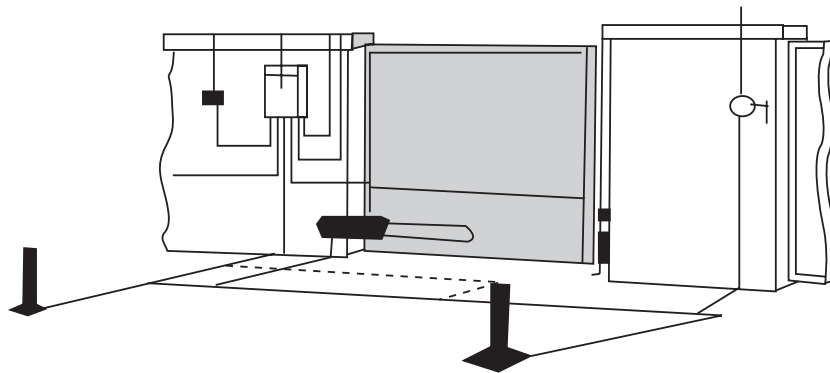

UNDER NO CIRCUMSTANCES SHOULD THIS EQUIPMENT BE OPERATED UNLESS FITTED TO A GATE.

FAILURE TO COMPLY WILL INVALIDATE THE GUARANTEE.

INSTALLATION INSTRUCTIONS

CONTENTS

1) Stage 1:- Civil & Mechanical Section		Page
1.1	BASIC HINGE GEOMETRY	3
1.2	BASIC CABLE LAYOUT	4
1.3	LOW VOLTAGE CABLE LAYOUT	5
1.4	ATTACHING BRACKETS	5
1.5	ATTACHING THE REAR BRACKET	6
1.6	ATTACHING THE FRONT BRACKET	7
2) Stage 2:- Wiring & Electrical		
2.1	FITING THE CONTROL PANEL IN THE CASING	9
2.2	GAINING ACCESS TO MOTOR	10
2.3	INSTALLING THE MOTOR	11
2.4	ADJUSTING OPEN/STOP LIMIT SWITCH	11
2.5	WIRING THE MOTOR	13
2.6	WIRING THE SAFETY PHOTOCELLS	14
2.7	INSERTING THE FREQUENCY CARD	14
2.8	WIRING IN THE TUNED ANTENNA	15
2.9	CODING THE REMOTE CONTROLS	15
2.10	POWERING UP THE CONTROL PANEL	15
3) Stage 3:- Commissioning the Control Panel		
3.1	INITIAL WIRING & CONTROL PANEL SETUP	17
3.2	OPENING & CLOSING THE GATE	18
3.3	CONTROL PANEL ADJUSTMENTS	19
3.4	AUTOMATIC CLOSE & SAFETY PHOTOCELLS	20
3.5	PROGRAMMING THE REMOTE CONTROLS TO THE CONTROL PANEL	21
4) Troubleshooting Guide		23
5) Technical Information		
5.1	TECHNICAL SPECIFICATIONS	25
5.2	MOTOR TORQUE SETTINGS	26
5.3	ZA5 CONTROL PANEL DESCRIPTION	27
5.4	ZA5 WIRING DIAGRAM	29
5.5	CONTROL PANEL ADJUSTMENTS	30
5.6	ELECTRICAL CONNECTIONS	31
6) Contact Information		



STAGE 1

CIVIL & MECHANICAL SECTION

1.1- Basic Hinge Geometry

BEFORE BEGINNING YOUR INSTALLATION OF YOUR ATI SYSTEM, CHECK THE FOLLOWING:

- * YOUR GATE PIERS OR POSTS ARE SUFFICIENTLY STRONG ENOUGH TO SUPPORT THE GATES AND OPERATORS AND THE GATES SWING FREELY AND THERE IS NO FRICTION BETWEEN THE MOVING PARTS.
- * MEASUREMENT **C** MUST NOT BE GREATER THAN THE VALUE SHOWN BELOW. IF THIS IS THE CASE, IT IS NECESSARY TO MODIFY THE PILLAR SO THAT THIS MEASUREMENT CORRESPONDS.

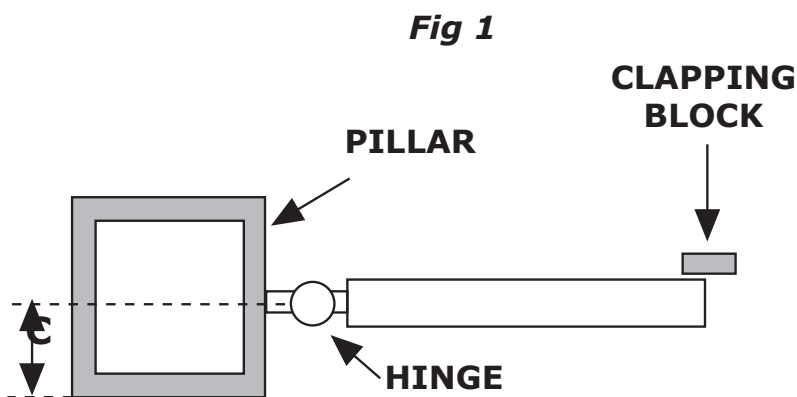

Dimension **C** must be no greater than 120mm for 90° opening and no greater than 70mm for a 130° opening.

- * ENSURE THAT THE CLAPPING BLOCK IS SECURELY ATTACHED TO THE PILLAR OR POST.

1.2 - Basic Cable Layout

THIS DIAGRAM DETAILS THE BASIC CABLE LAYOUT FOR A SINGLE MOTOR.

THE POWER SUPPLY TO THE CONTROL PANEL SHOULD BE LIVE AND PROTECTED IN ACCORDANCE WITH THE 16TH EDITION ELECTRICAL REGULATIONS. THE SUPPLY SHOULD BE RATED AT A MINIMUM OF 6 AMPS. WHEN INSTALLING WIRES OUTDOORS THE CABLE APPROACH TO ALL DEVICES MUST BE FROM BELOW TO CREATE A "DRIP-LOOP" AND THEREBY AVOID UNNECESSARY WATER INGRESS.

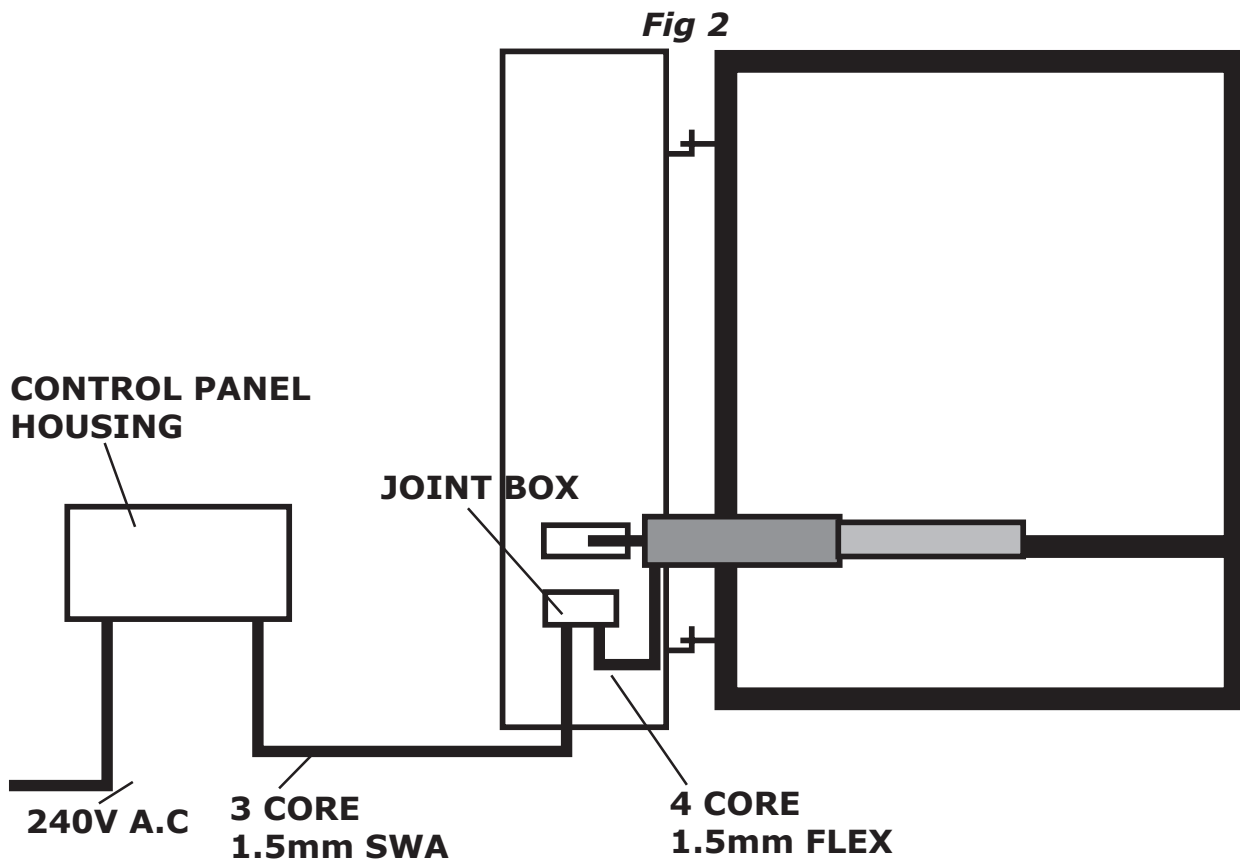

WHEN INSTALLING LOW VOLTAGE CABLE AROUND THE GATEWAY IT IS ADVISED TO PUT ALL LOW VOLTAGE CABLE IN EITHER DUCTING OR ALKATHENE PIPING. ALL CABLE JOINTING SHOULD BE CARRIED OUT ABOVE GROUND.

1.3 - Low Voltage Cable Layout

ALL CAME ACCESSORIES CAN BE WIRED 0.2m STRANDED CABLE (BUGLAR ALARM TYPE). THE TUNED ANTENNA SHOULD BE WIRED WITH COAXIAL CABLE (RG59).

Fig 3

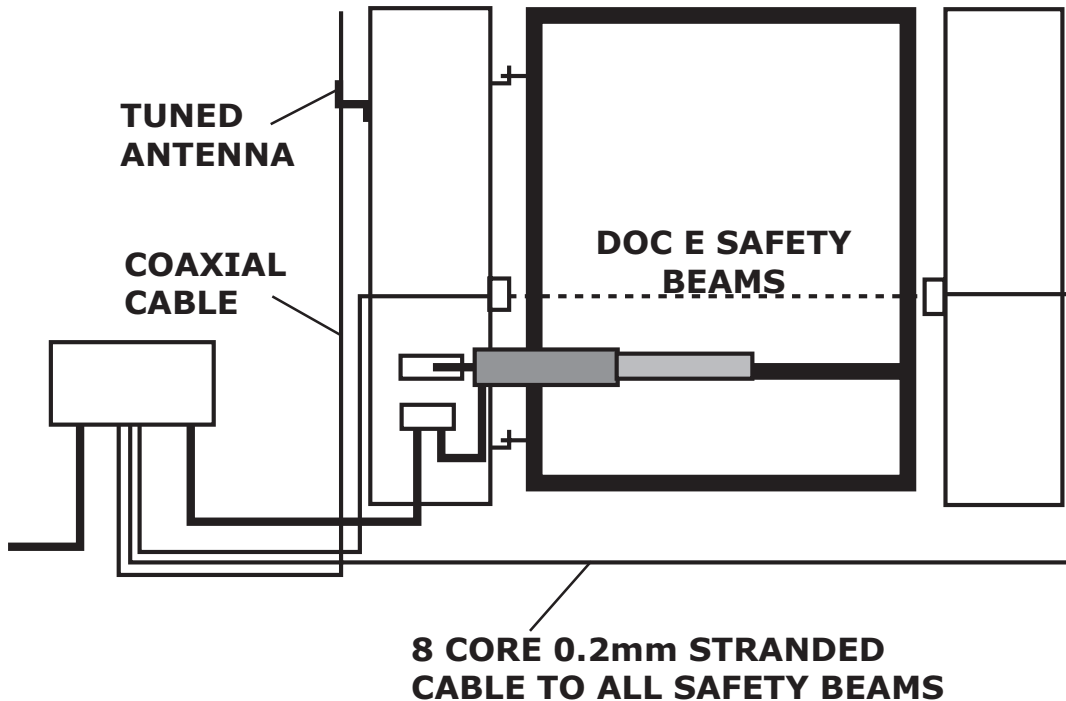

1.4 - Attaching Brackets

WELD THE 9 HOLE BRACKET TO THE FIXING PLATE THEN SECURELY ATTACH THE FIXING BRACKET TO THE PIER OR POST, OBSERVE MEASUREMENT **A** AND **B** BETWEEN THE HINGE PIN AND THE CENTRAL HOLE IN THE BRACKET.

Fig 4

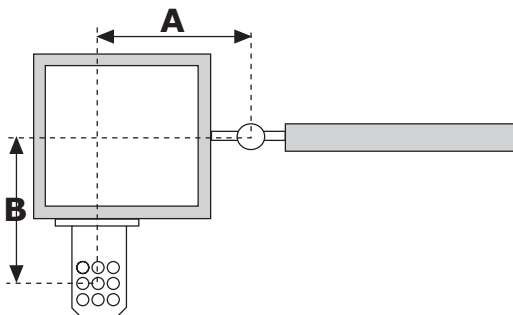

Opening	A mm	B mm
90°	200	200
130°	200	140

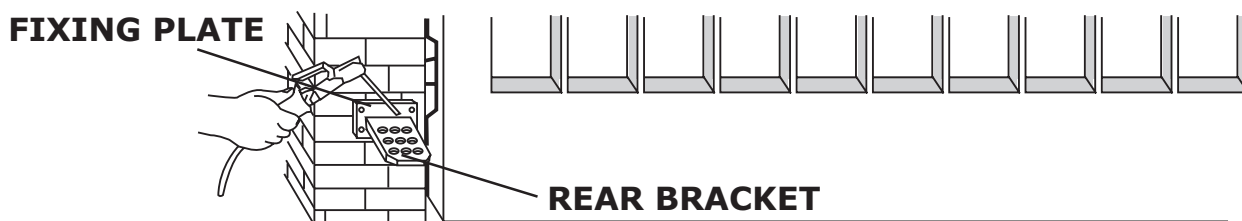

THE REAR BRACKET IS EQUIPPED WITH ADDITIONAL HOLES TO MAKE INSTALLATION OF THE GATE MOTOR EASIER, OR TO CHANGE THE OPENING ANGLE OF THE GATE. THE REAR BRACKET CAN BE LENGTHENED OR SHORTENED TO SUIT THE INDIVIDUAL INSTALLATION SITE AND THE POSITION OF THE GATES (WITH RESPECT TO THE PILLARS).

N.B IF MEASUREMENT **B** IS INCREASED, THE ANGLE OF APETURE IS REDUCED. THIS THEREFORE REDUCES THE PERIPHERAL SPEED AND INCREASES THE THRUST EXERTED BY THE MOTOR ON THE GATE. IF MEASUREMENT **A** IS INCREASED, THE ANGLE OF APERTURE IS INCREASED. THIS THEREFORE INCREASES THE PERIPHERAL SPEED AND REDUCES THE THRUST EXERTED BY THE MOTOR ON THE GATE.

WHEN THE REAR BRACKET IS SECURELY ATTACHED TO THE PIER OR POST, INSERT THE BUSH INTO THE DESIRED HOLE AND ATTACH THE REAR JOINT ARM, LUBRICATING WITH A NEUTRAL GREASE.

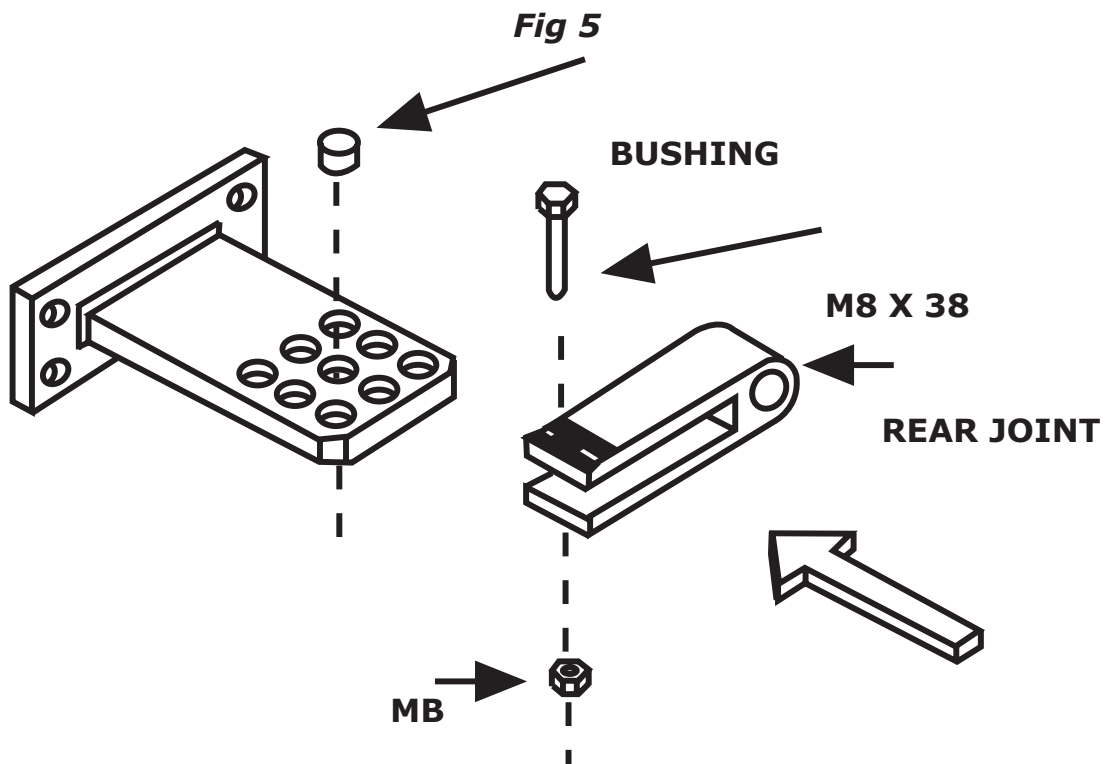

WITH THE GATE IN THE FULLY CLOSED POSITION WELD THE FRONT BRACKET TO THE FIXING PLATE THEN ATTACH IT TO THE GATE. THE ANCHOR PLATE MUST BE HORIZONTALLY ALIGNED WITH THE REAR BRACKET MOUNTED ON THE PEIR OR POST ENSURING DIMENSION IS OBSERVED.

N.B WHEN INSTALLING THE UNIT ON SPECIAL FRAMES, IT MAY BE NECESSARY TO FIT ADDITIONAL SPACERS WITH A MINIMUM THICKNESS OF 10mm IN ORDER TO PREVENT CONTACT BETWEEN THE OPERATOR AND THE GATE WING.

Fig 6

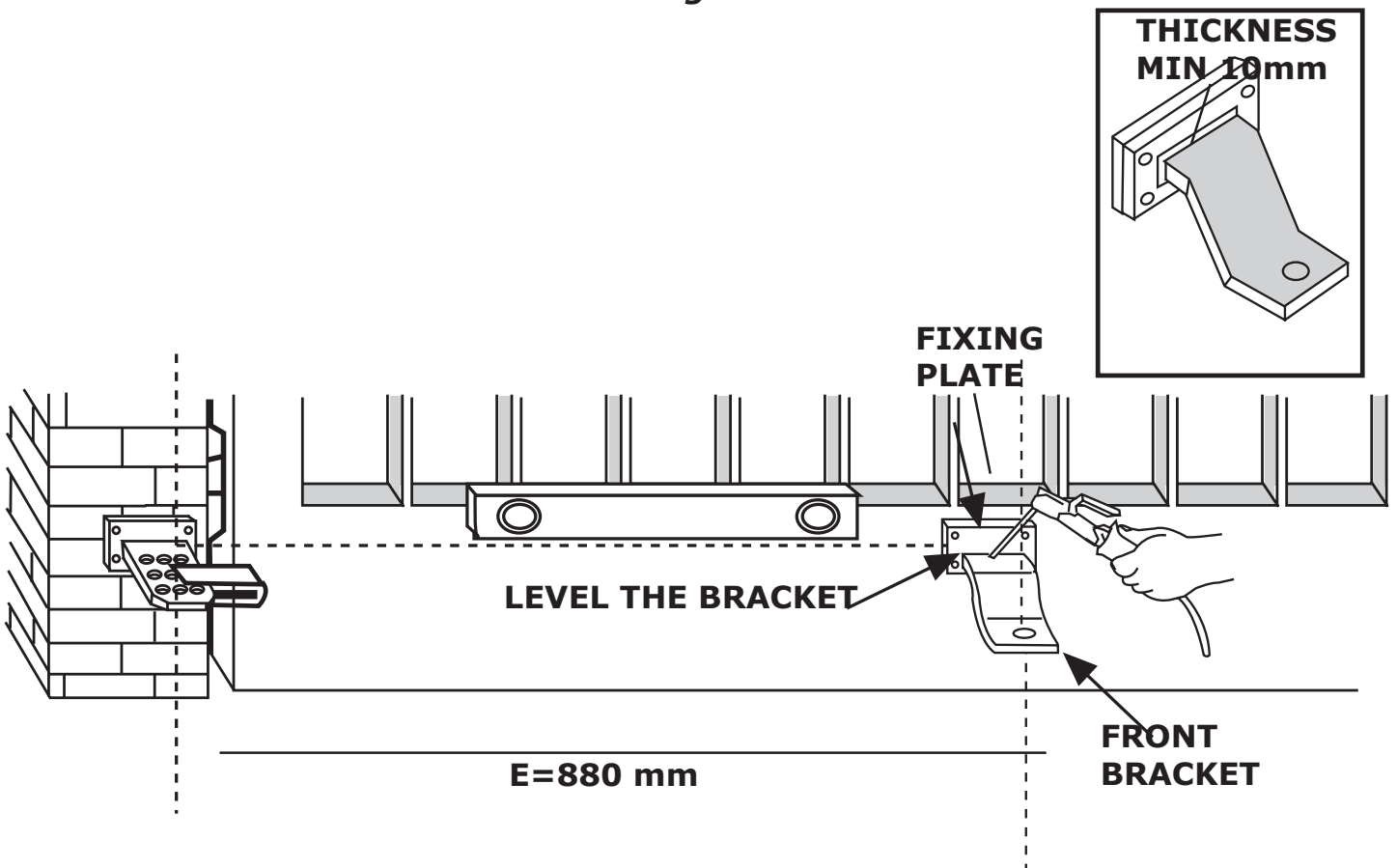

END OF INSTALLATION STAGE 1

**BEFORE STARTING STAGE 2 - Wiring & Electrical
PLEASE CHECK THAT YOU HAVE CORRECTLY:**

Page		Ref	
	1. PREPARED THE CABLING CORRECTLY	1.2	4
	2. CORRECTLY ATTACHED THE BRACKETS	1.4	5

**NOW STAGE 1 IS FULLY COMPLETED YOU ARE READY TO
BEGIN STAGE 2 OF YOUR ATI AUTOMATION KIT
INSTALLATION**

STAGE 2 - WIRING & ELECTRICAL

2.1 - Fitting the Control Panel in the Casing

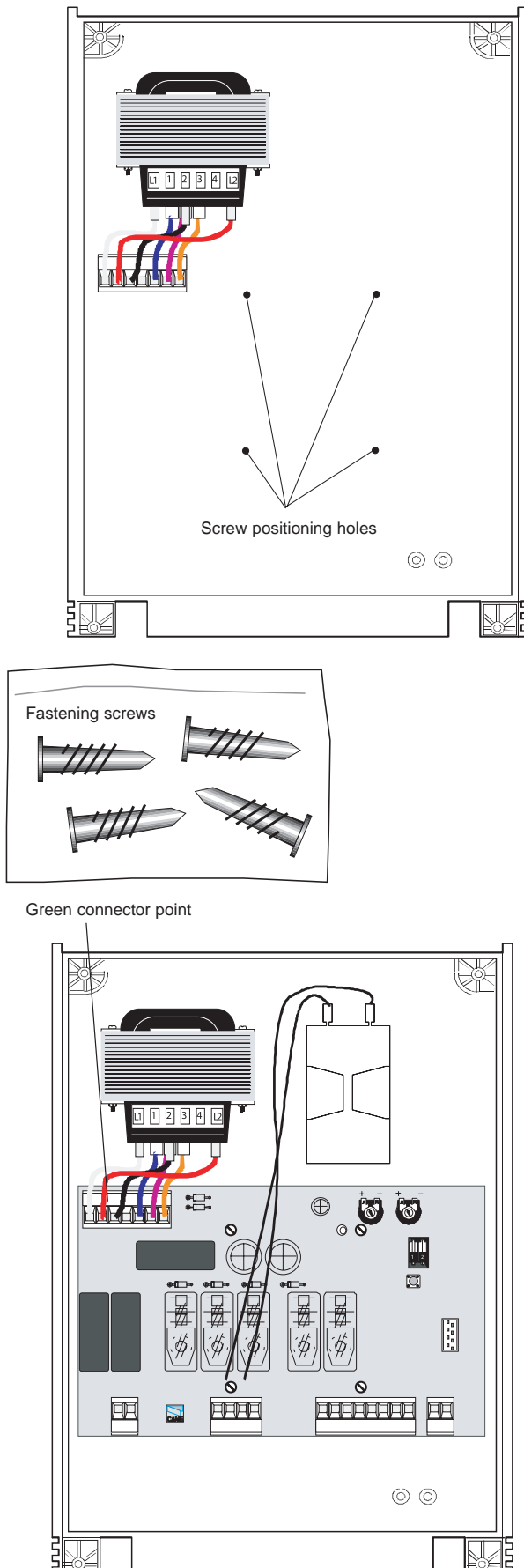

Securely fasten the control panel PCB to the casing with the screws supplied.

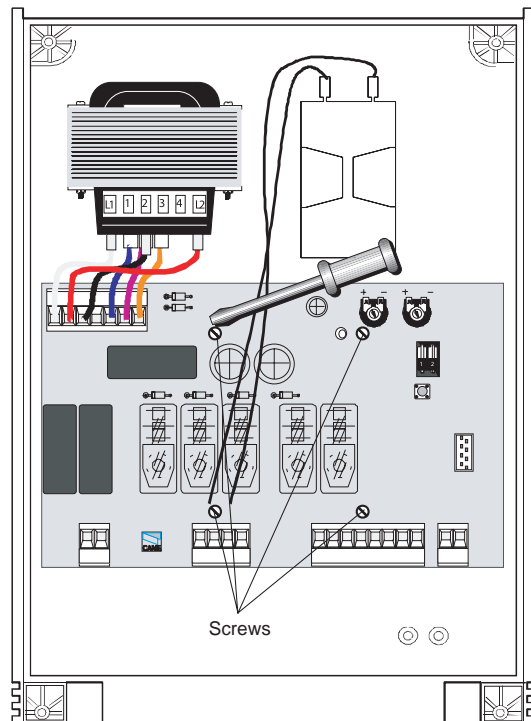

Plug the green connector from the transformer to the PCB ensuring that it connects the correct way.

NB FROG Series Motors: connect the black wires coming out of the board to one capacitor.

2.2 - Gaining Access to the Motors

TO GAIN ACCESS TO THE MOTOR TERMINALS AND WORM DRIVE FIRST REMOVE THE COVERS. FIRST REMOVE THE SCREWS FROM THE TOP COVER. THEN REMOVE THE TWO SCREWS THAT SECURE THE WORM DRIVE COVER.

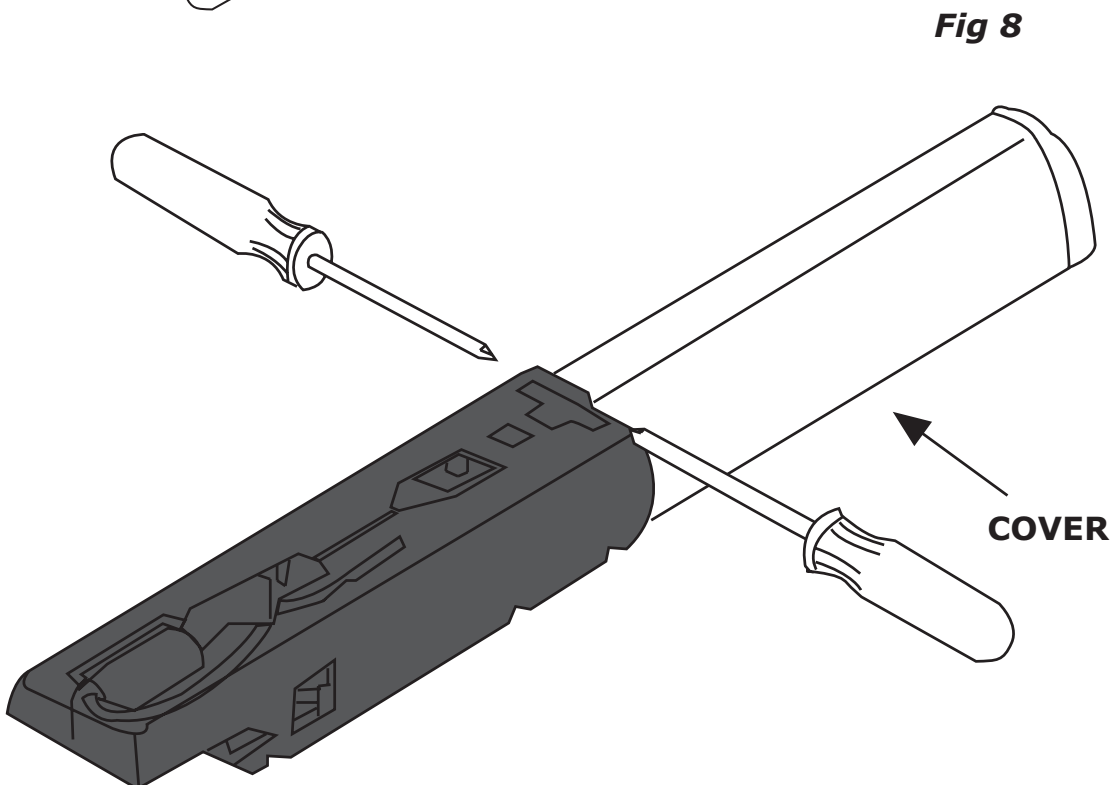
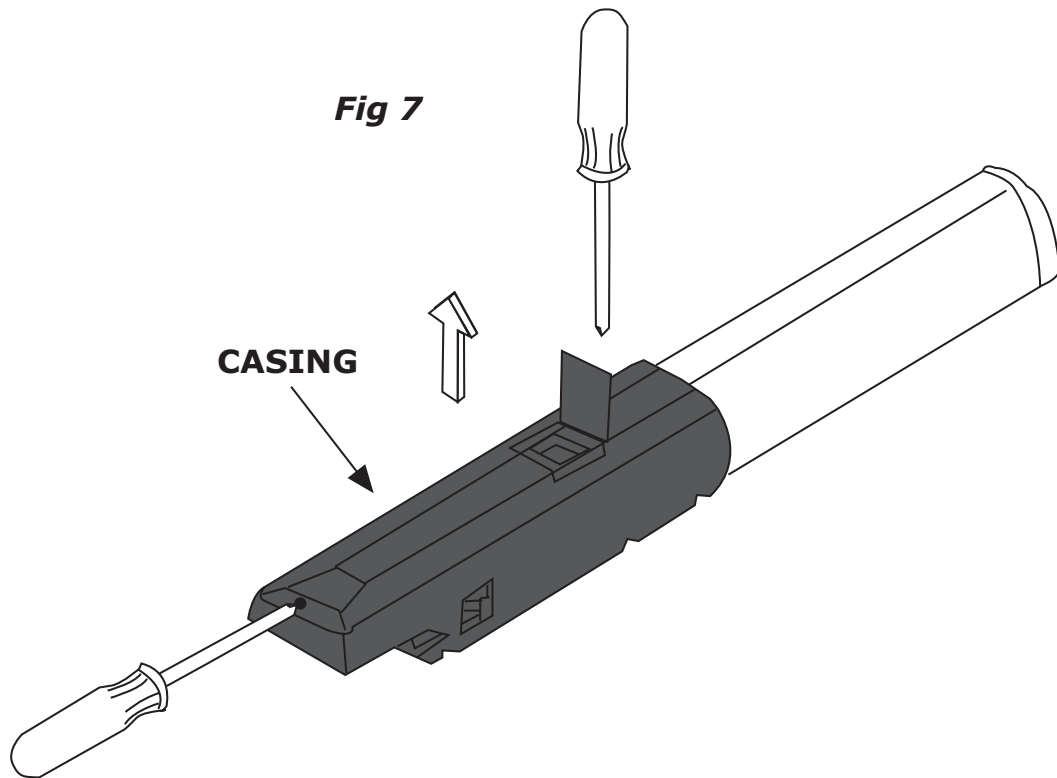

2.3 - Installing the Motor

WITH THE COVERS REMOVED INSTALL THE MOTOR ON THE TWO BRACKETS AND SECURE THE MOTOR WITH THE NUTS AND BOLTS PROVIDED.

Fig 9

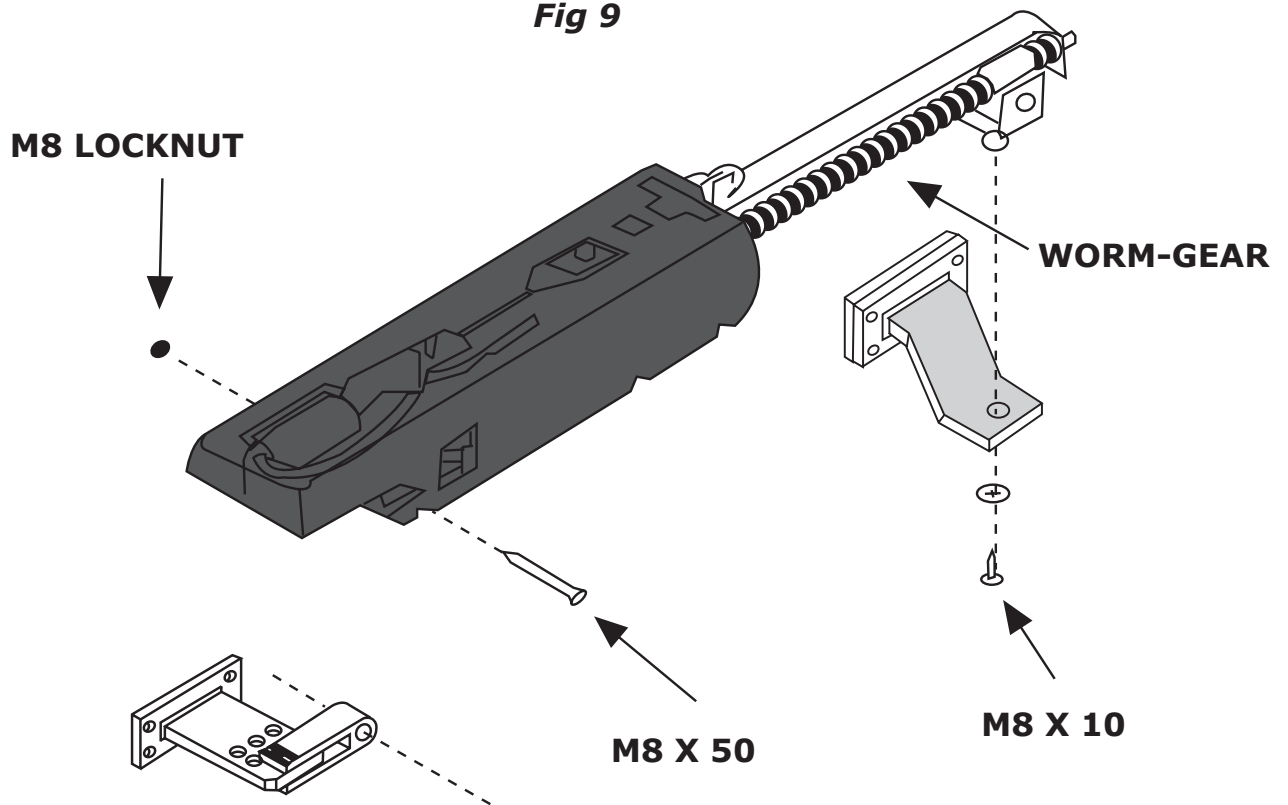

2.4 - Adjusting the Open Stop Microswitch

MANUALLY RELEASE THE REDUCTION GEAR BY INSERTING THE RELEASE KEY AND TURNING IT 180°.

Fig 10

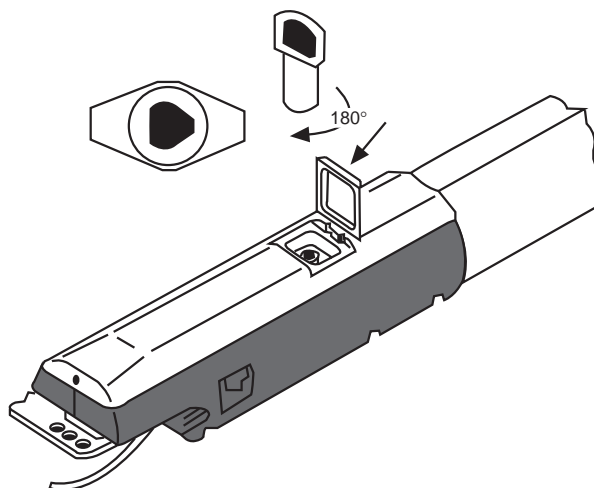

MOVE THE GATE TO THE DESIRED OPEN POSITION. LOOSEN THE SCREWS WHICH HOLD THE MICROSWITCH IN POSITION. SLIDE THE MICROSWITCH ON THE SUPPORT PLATE UNTIL THE MICROSWITCH IS TRIPPED. THEN TIGHTEN THE SCREWS TO ANCHOR THE MICROSWITCH IN POSITION.

Fig 11

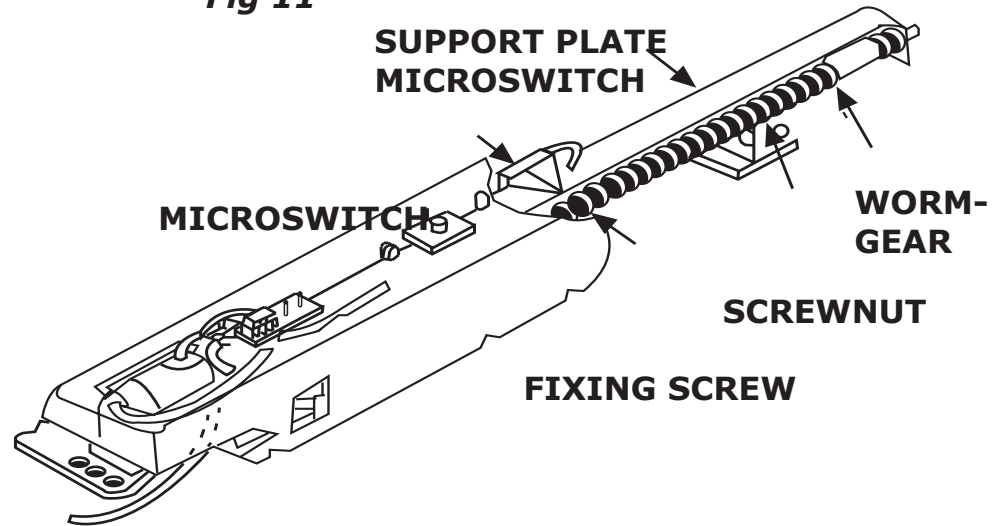

2.5 - Wiring the Motor

ENSURE THAT THE MOTOR IS ADEQUATELY EARTHED.

Fig 12

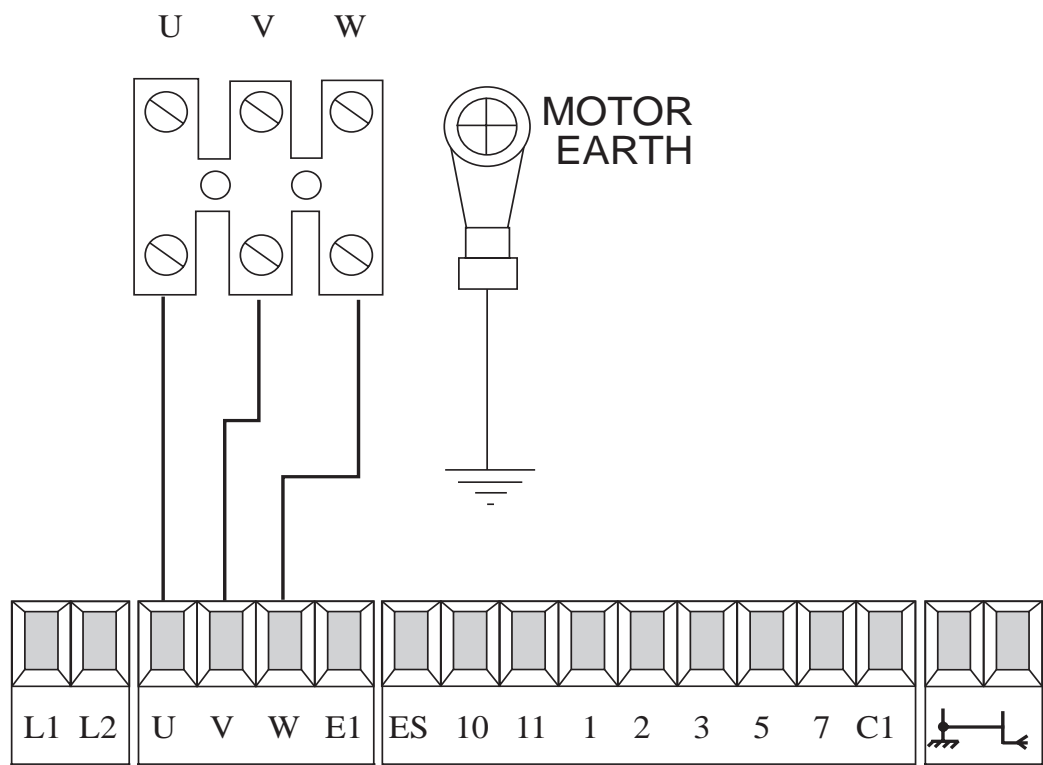

2.6 - Wiring in the Safety Photocells

SAFETY BEAMS SHOULD BE FITTED APPROXIMATELY
15 INCHES FROM GROUND LEVEL

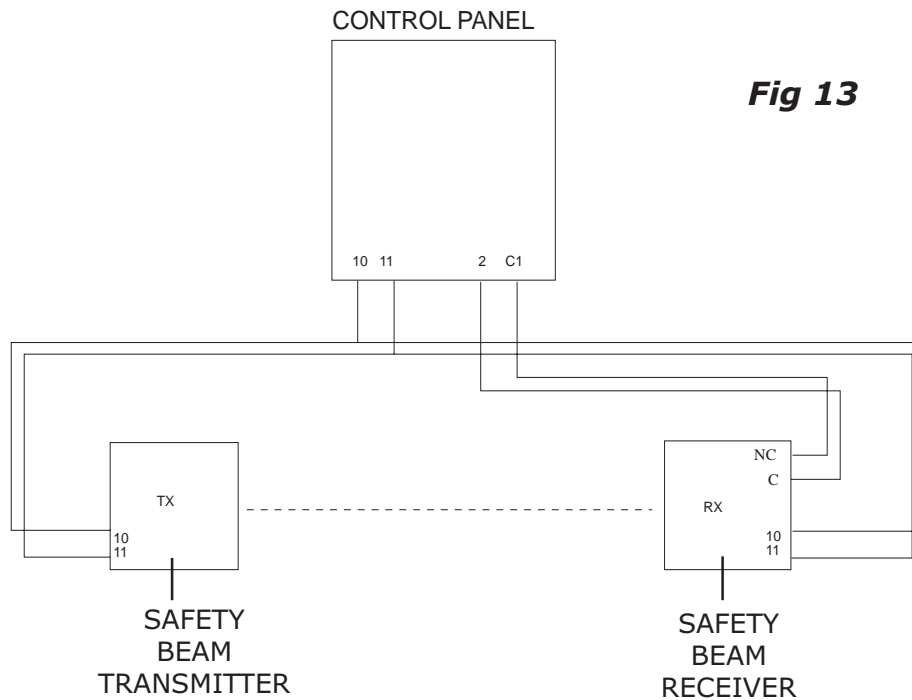

Fig 13

IF FITTING A SECOND ARC LINE OF SAFETY BEAMS THEN C & NC MUST BE WIRED IN "SERIES"

2.7 - Inserting the Radio Frequency Card

Fig 14

INSERT THE RADIO FREQUENCY
CARD INTO THE SMALL SOCKET
ON THE CONTROL PANEL
(ENSURE THAT THE POWER IS
TURNED **OFF** TO THE CONTROL
PANEL BEFORE INSERTING THE
FREQUENCY CARD)

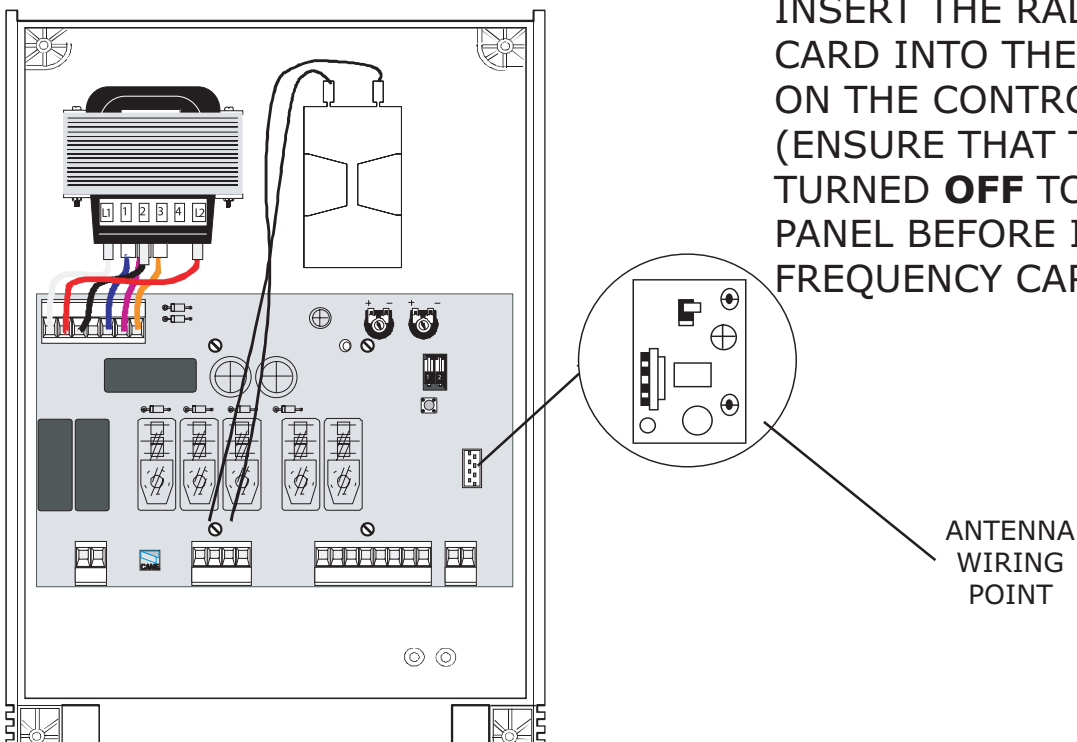

2.8 - Wiring in the Tuned Antenna

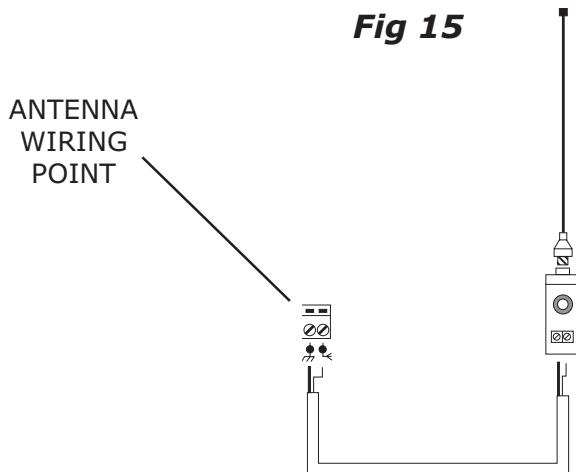

2.9 - Coding the Remote Controls

1. REMOVE THE BATTERY COVER & CASING OF THE REMOTE CONTROL HANDSET TO REVEAL THE DIAGRAM BELOW

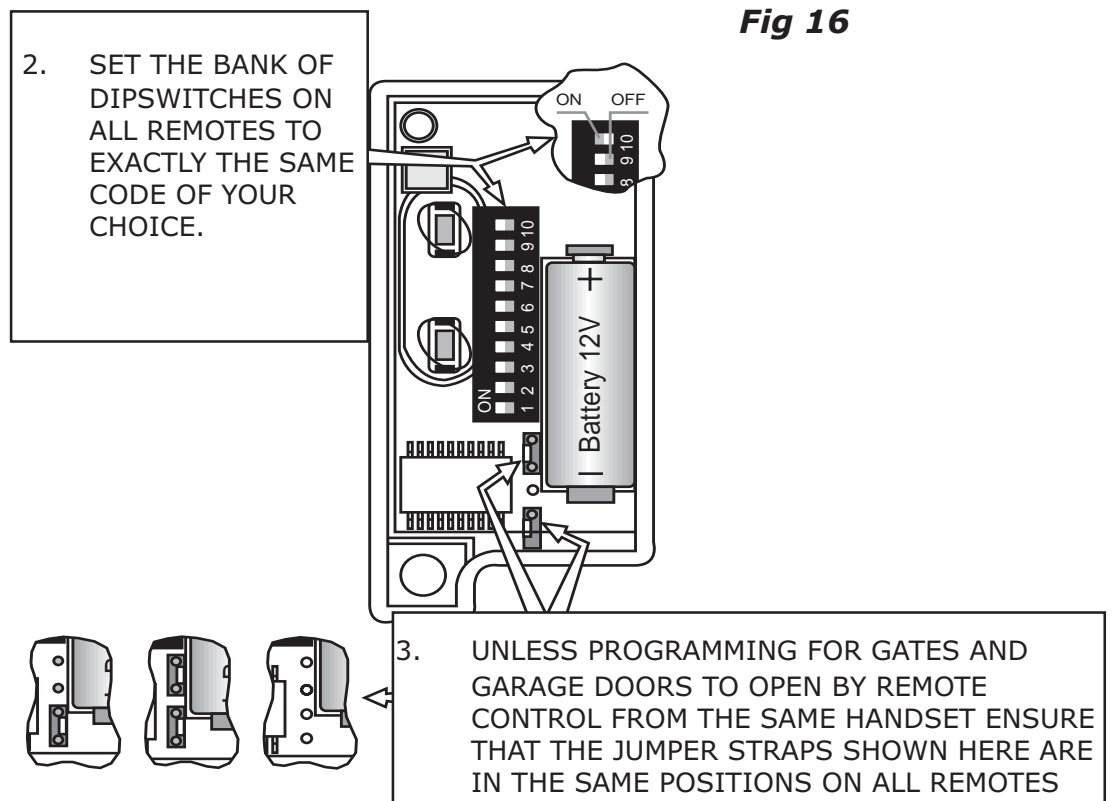

2.10 - Powering up the Control Panel

CONNECT PROTECTED MAINS POWER TO TERMINALS L1 + L2 IN THE CONTROL PANEL (**L2 BEING LIVE!**). ENSURE THAT THE CONTROL PANEL IS ADEQUATELY EARTHED.

END OF INSTALLATION STAGE 2

BEFORE STARTING STAGE 3 - Commissioning the Control Panel

PLEASE CHECK THAT YOU HAVE CORRECTLY:

	Ref	Page
1. FITTING THE CONTROL PANEL IN THE CASING	2.1	9
2. GAINED ACCESS TO MOTOR	2.2	10
3. INSTALLED MOTOR	2.3	11
4. ADJUSTED OPEN/STOP LIMIT SWITCH	2.4	11
5. WIRED THE MOTORS	2.5	13
6. WIRED THE SAFETY PHOTOCELLS	2.6	14
7. INSERTING THE FREQUENCY CARD	2.7	14
8. WIRED THE TUNED ANTENNA	2.8	15
9. CODED THE REMOTE CONTROLS	2.9	15
10. POWERED UP THE CONTROL PANEL	2.10	15

**NOW STAGE 2 IS FULLY COMPLETED YOU ARE READY TO
BEGIN STAGE 3 OF YOUR ATI AUTOMATION KIT
INSTALLATION**

STAGE 3

COMMISSIONING THE CONTROL PANEL

3.1 - Initial Wiring & Control Panel Setup

Fig 17

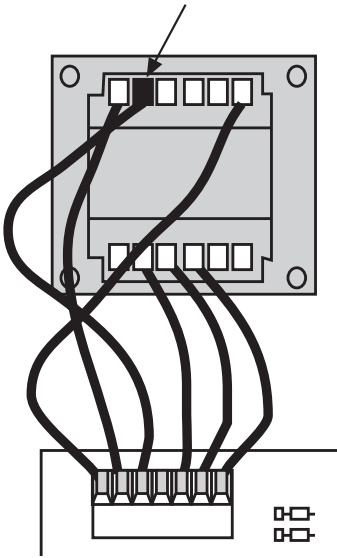

1. CONNECT POWER TERMINALS L1 - L2 AND A SUITABLE EARTH (**L2 BEING LIVE!**)
2. SELECT THE MOTOR POWER SETTING ON THE TRANSFORMER TO LEVEL 1 FOR COMMISSIONING

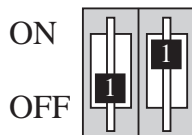

Fig 18

3. SELECT DIPSWITCHES 1 & 2 OFF FOR COMMISSIONING
4. ENSURE HARD WIRE LINK IS FITTED BETWEEN TERMINALS 1 & 2 AND 2 & C1

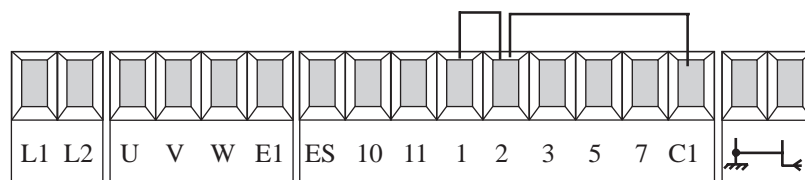

Fig 19

3.2 - Opening & Closing the Gate

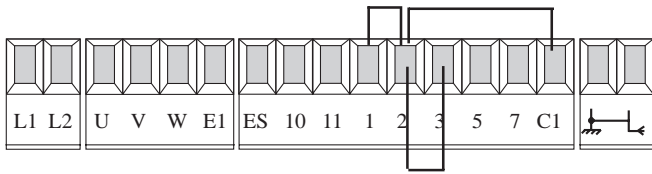

Fig 20

1. MOMENTARILY PULSE TERMINALS 2 & 3 WITH A PIECE OF WIRE TRAILING FROM TERMINAL 2 AND MOMENTARILY TOUCHING TERMINAL 3.

THE GATE SHOULD START TO OPEN. IF THE MOTOR STARTS TO CLOSE TURN THE POWER OFF TO THE CONTROL PANEL AND CHANGE AROUND X-Y (MOTOR 2) TO CHANGE THE MOTOR DIRECTION.

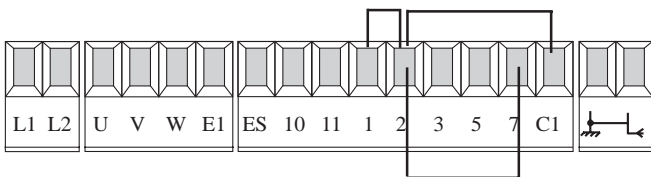

Fig 21

2. ONCE YOU HAVE PROVED THE MOTOR DIRECTION USE TERMINALS 2 & 7 TO OPEN AND CLOSE THE GATES WITH A TRAILING WIRE ONCE AGAIN INTO TERMINAL 2, MOMENTARILY TOUCHING TERMINAL 7.

3.3 - Control Panel Adjustments

1. TO DELAY ONE GATE LEAF, ADJUST POTENIOMETER TR2M TO DELAY THE CLOSING OF GATE NO. 2 IN THE CLOSING CYCLE

Fig 22

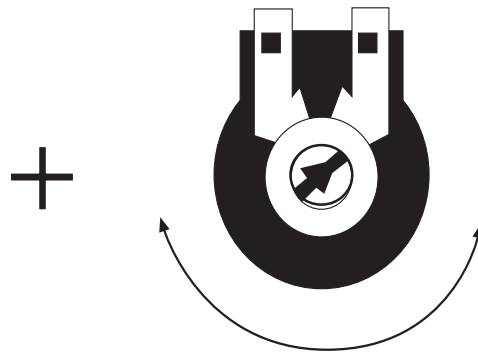

TRIMMER TR2M

N.B ALWAYS SET TR2M TO MINIMUM FOR SINGLE GATE INSTALLATIONS

2. TO SET THE TOTAL RUNNING TIME OF THE MOTORS, ADJUST POTENIOMETER TL TO ALLOW THE MOTORS TO RUN FOR A FURTHER 5-7 SECONDS AFTER THE MOVEMENT CYCLE HAS BEEN COMPLETED (I.E FULLY OPEN OR FULLY CLOSED)

Fig 23

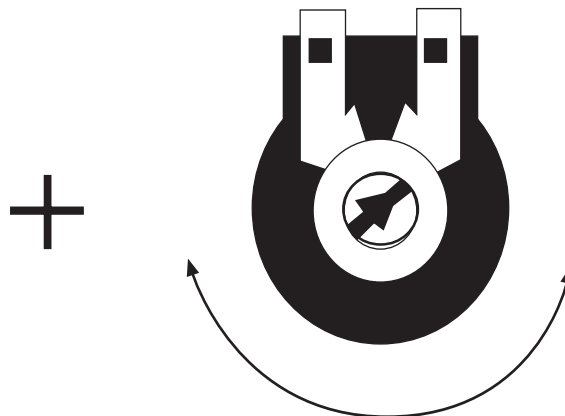

TRIMMER TL

3. CHECK THE SENSITIVITY OF THE GATE BY TRYING TO PHYSICALLY STOP THE GATE AND ADJUST THE POWER SETTINGS ON THE TRANSFORMER ACCORDINGLY. IF MORE POWER IS NEEDED FOR A HEAVIER GATE THEN SWITCH OFF POWER AND MOVE TRANSFORMER WIRE UP TO SETTING 2. FOR RECHECKING SENSITIVITY, REPEAT PROCESS UP TO 3 OR 4 IF EVEN MORE POWER IS NEEDED.

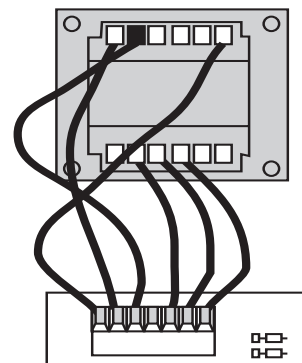
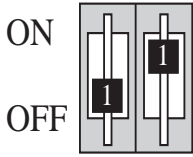

Fig 24

3.4 - Automatic Close & Activating Safety Photocells

Fig 25



1. TO SELECT AUTOMATIC CLOSING,
SELECT DIPSWITCH 2 **ON**.

SET THE AUTOMATIC CLOSING TIME BY ADJUSTING POTENTIOMETER TCA

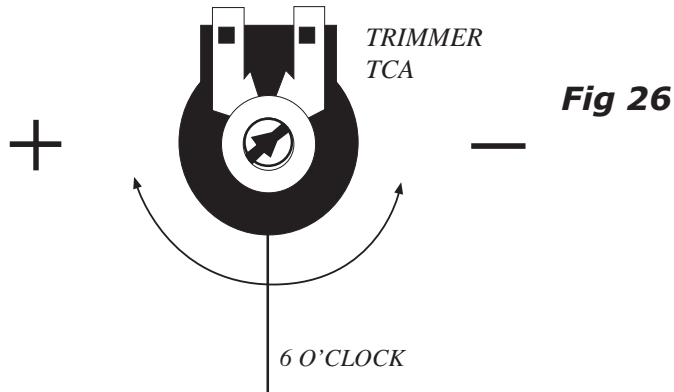

FULLY ANTI-CLOCKWISE WILL APPROX. AUTOMATICALLY CLOSE THE GATE AFTER 10 SECONDS AND FULLY CLOCKWISE WILL APPROX. CLOSE THE GATE AFTER 80 SECONDS. A SENSIBLE SETTING IS ABOUT HALFWAY (I.E 6 O'CLOCK POSITION) WHICH WILL AUTOMATICALLY CLOSE THE GATES AFTER APPROX. 30 SECONDS.

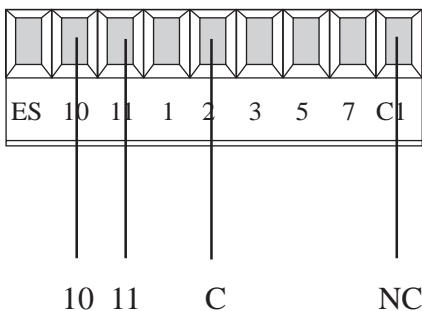

2. FOR RE-OPENING DURING CLOSING.
REMOVE HARD WIRE LINK BETWEEN 2 & C1 AND INSERT SAFETY BEAM WIRES AS SHOWN.

Fig 27

3.5 - Programming the Remote Controls to the Control Panel

To use the remote control system, proceed as follows:

- A) Turn power OFF and insert AF radio frequency board then turn power back on
- B) Code the transmitter. See the relevant instruction sheet (See Fig 11)
- C) To store the code on the circuit board Proceed as follows:

Press and hold down the YellowCH1 button on the radio receiver card (the signal LED will start to flash)

At the same time transmit on the top button of your remote control; keep both the top button and the yellow receiver button pressed until the LED stops flashing and remains on constant to indicate that the code has been successfully stored.

N.B. If you wish to change the code on your transmitter in the future, simply repeat the procedure above with all the remotes on the installation.

WARNING: Disconnect the power supply from the control board before inserting OR removing the AF radio-frequency card from the socket.

END OF INSTALLATION STAGE 3

PLEASE CHECK THAT YOU HAVE CORRECTLY:

	Ref	Page
1. SET POWER SETTING, INSERTED MOTOR CAPACITORS, SET DIPSWITCHES FOR COMMISSIONING, ENSURE WIRE LINK IS FITTED BETWEEN TERMINALS 1 & 2 AND 2 & C1	3.1	12
2. SET THE OPENING AND CLOSING TIMES FOR GATES	3.2	13
3. ADJUSTED THE CONTROL PANEL	3.3	14
4. IF REQUIRED, ACTIVATED AUTOMATIC CLOSING AND SAFETY PHOTOCELLS	3.4	15
5. PROGRAMMED THE REMOTE TO THE CONTROL PANEL	3.5	16

4. TROUBLESHOOTING GUIDE

A MULTIMETER WILL BE NEEDED

<i>PROBLEM</i>	<i>SOLUTION</i>
GATE WILL NOT RESPOND WHEN GIVEN A COMMAND	<ol style="list-style-type: none">1. CHECK POWER SUPPLY TO THE CONTROL PANEL.2. CHECK CONTROL PANEL FUSES.3. CHECK HARD WIRE LINK FITTED BETWEEN TERMINALS 1 & 2.
GATE IS OPEN BUT WILL NOT CLOSE AND GREEN LED IS FLASHING	<ol style="list-style-type: none">1. CHECK SAFETY BEAMS ARE WIRED CORRECTLY. (IF MORE THAN ONE SET OF BEAMS ARE FITTED THEY MUST BE WIRED IN SERIES.)2. CHECK THAT THERE IS POWER GOING TO THE BEAMS, IF NOT RESTORE POWER.3. IF SAFETY BEAMS ARE NOT FITTED ENSURE THAT A HARD WIRE IS FITTED BETWEEN TERMINALS 2 & C1.4. REMOVE SAFETY BEAM WIRES 2 & C1 FROM CONTROL PANEL AND CHECK IF YOU HAVE A NORMALLY CLOSED CIRCUIT COMING FROM THE BEAMS.
WHEN COMMISSIONING GATE AUTOMATICALLY OPEN BUT DO NOT AUTOMATICALLY CLOSE	<ol style="list-style-type: none">1. MOTOR WIRES ARE WRONG WAY ROUND. CHECK AND PROVE MOTOR DIRECTION BY MOMENTORIALY PULSING TERMINALS 2 & 3. THE GATE SHOULD OPEN UP. TURN AUTOMATIC CLOSING <i>OFF</i> (DIP SWITCH 2) UNTIL MOTOR DIRECTION HAS BEEN PROVED.

CONTINUED ON NEXT PAGE

<i>PROBLEM</i>	<i>SOLUTION</i>
<p>GATE WILL NOT RESPOND TO REMOTE CONTROL COMMAND</p>	<ol style="list-style-type: none"> 1. AF FREQUENCY CARD NOT FITTED TO CONTROL PANEL. 2. REMOTE CONTROL HAS NOT BEEN PROGRAMMED INTO THE CONTROL PANEL. 3. REMOTE CONTROL HAS THE WRONG CODE SETTING. 4. "OPERATOR PRESENT" HAS NOT BEEN SELECTED TO DEACTIVATE RADIO REMOTE CONTROLS (DIPSWITCH 1). 5. WRONG FREQUENCY CARD FITTED FOR THE REMOTE CONTROL.

IF THE PROBLEM IS STILL APPARENT CONTACT THE CAME TECHNICAL HELPLINE:

0115 938 7200

THIS INSTALLATION WAS COMPLETED BY:

.....

NAME.....

ADDRESS.....

.....

.....

.....

TEL..... MOBILE.....

DATE OF INSTALLATION.....

5. TECHNICAL INFORMATION

5.1 - Technical Specification

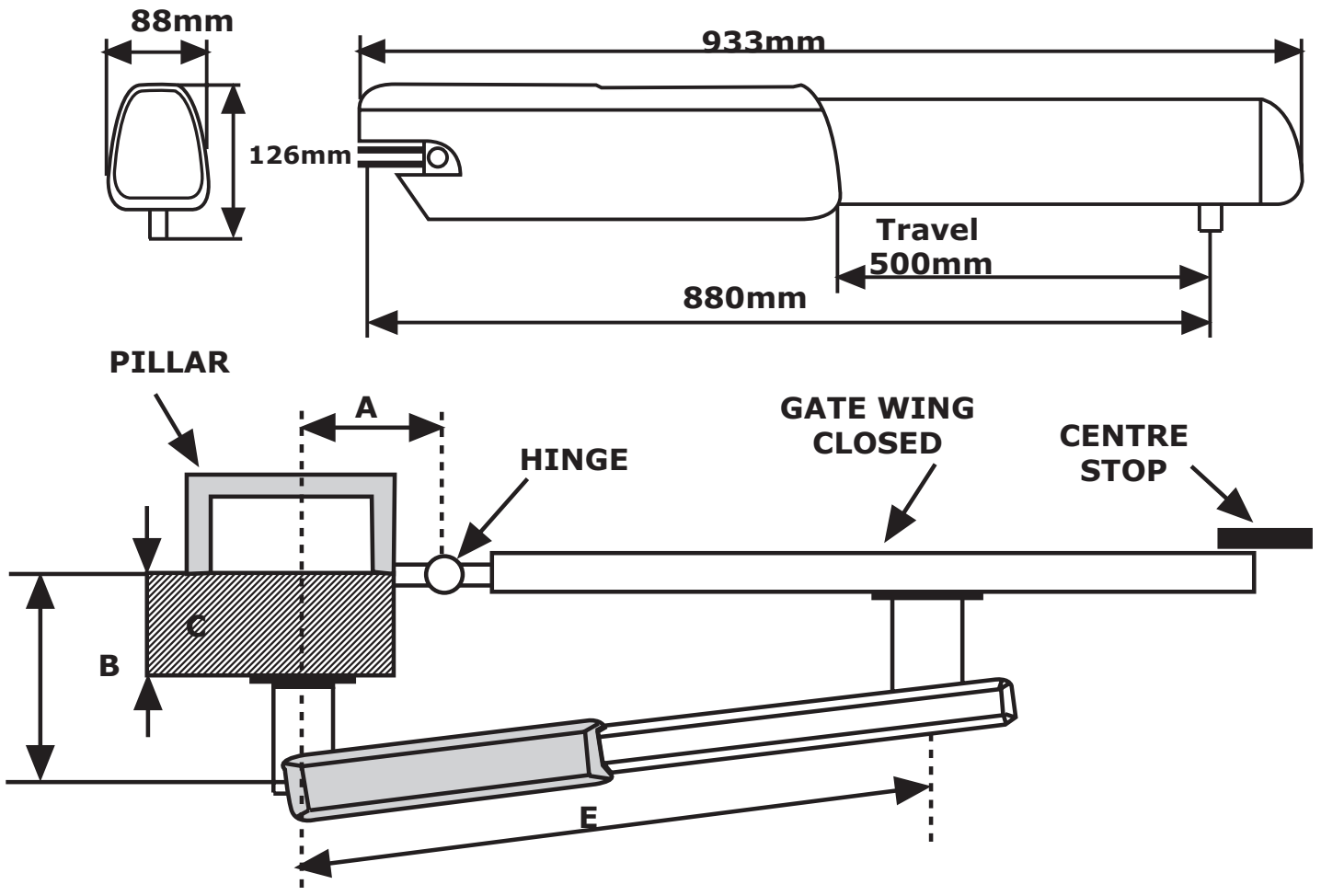

TYPE	OPENING	A mm	B mm	C Max mm	E mm
A5000	90 DEGREES	200	200	120	880
	130 DEGREES	200	140	70	880

WIDTH OF GATE WING (M)	WEIGHT OF GATE WING (KG)
2.00	1000
2.50	800
3.00	600
4.00	500
5.00	400

For particularly heavy gates, two motors per leaf can be fitted. In this case the weight indicated for the gate can be doubled.

GEAR	VERSION	WEIGHT	POWER	NOMINAL	POWER	DUTY	REDUCTION	PUSH	CAPACITOR
A5000	1.2	11Kg	230V	1.2A	150W	50%	1/36400	400/ 3000*N	10uF

5.2 - Motor Torque Settings

SEE ALSO PAGE 14

To vary the motor torque, move the indicated spade connector to one of the four position : 1=min, 4=max.

N.B. It is always best to start from position one and increase the torque setting as required.

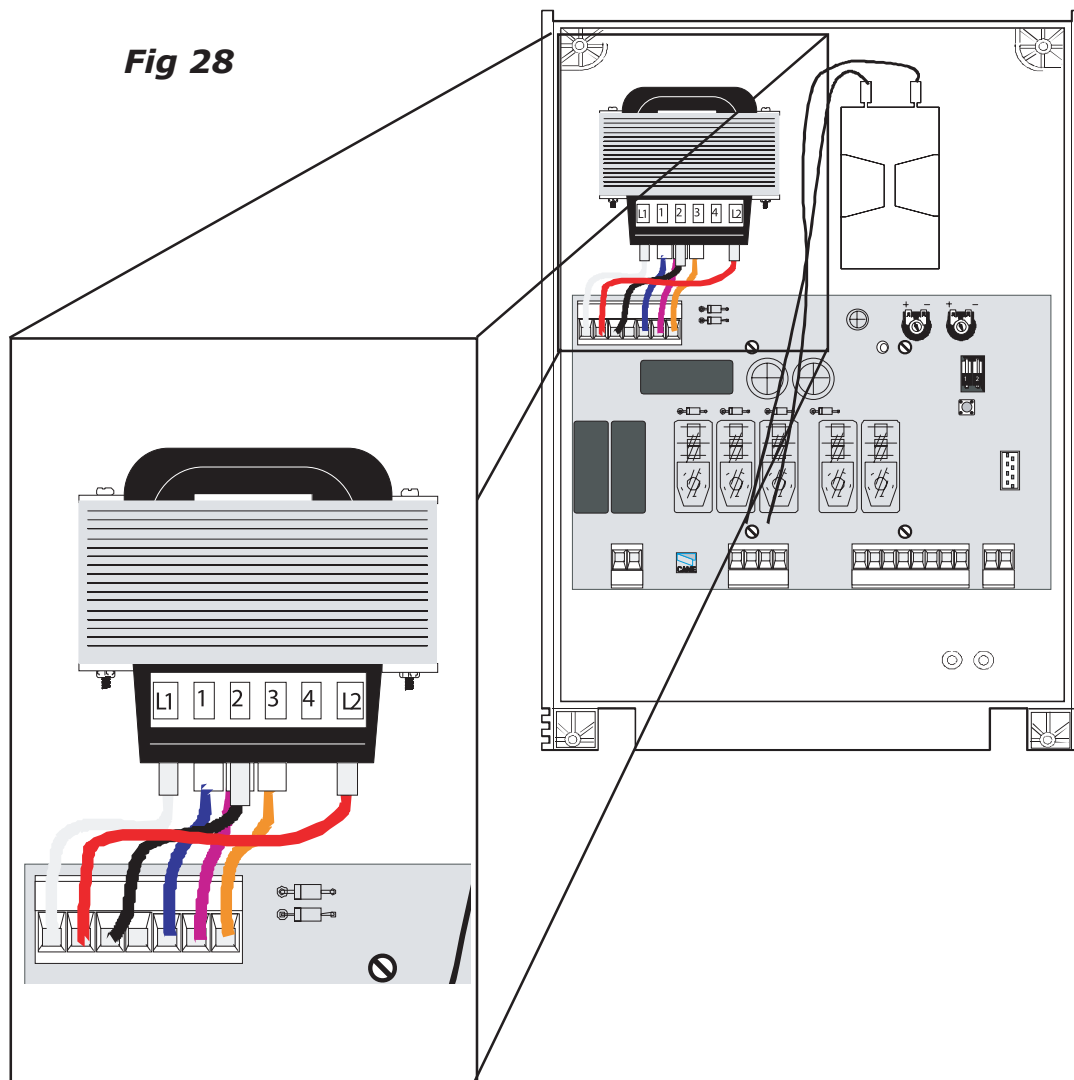

5.3 - ZA5 Control Panel Description

Description of Control Panel:

Micro-processor controlled electrical cabinet powered by 230V (a/c) at 50-60Hz, single phase. Designed for control of CAME (ATI/FERNI/FROG), for hinged gates, hinged industrial doors. Designed and built entirely by CAME to meet UNI8612 safety standards at an IP 54 level of protection. Housing made of ABS is equipped with vents to provide internal air circulation. Guaranteed for 3 years, unless tampered with. This control panel is powered 230V a.c across terminals L1 and L2, and is protected by a 5A fuse on the main power line. Control systems are powered by low voltage and protected by a 2A fuse. The accessories total wattage (24V) must not exceed 20W.

The Control Panel and Motors should be suitably Earthed

Safety:

SAFETY BEAMS CAN BE CONNECTED TO OBTAIN:

Re-Opening: During closing (2-C1), if the beam is broken while the gate is closing, they will reverse the direction of movement until the gate is completely open and will stay open until the obstacle is removed.

Total Stop: (1-2) Creates immediate stop of gate movement without automatic closing: (a pushbutton or radio remote control must be actuated to resume movement).

N.B IF A NORMALLY CLOSED SAFETY CIRCUIT (2-C1, 1-2) IS OPENED, THE L.E.D WILL FLASH TO INDICATE THE FACT THAT THE BEAM IS BROKEN.

Accessories that can be Connected to this Unit:

"Gate in Motion" Lamp: The lamp that lights the manoeuvring zone: it remains lit from the the moment the gate begins to open until they are completely closed (including the time required for the automatic closure). When automatic closure is not enabled, the lamp remains lit only during movement (E-E3).

Other functions available:

Automatic closing: The automatic closing timer is automatically activated at the end of the opening cycle. The pre-set, adjustable automatic closing time is automatically interrupted by the activation of any safety system, and is deactivated after a STOP command or in case of power failure.

"Operator present" function:

Gate operates only when the pushbutton is held down (the radio control system is deactivated)

Fig 29

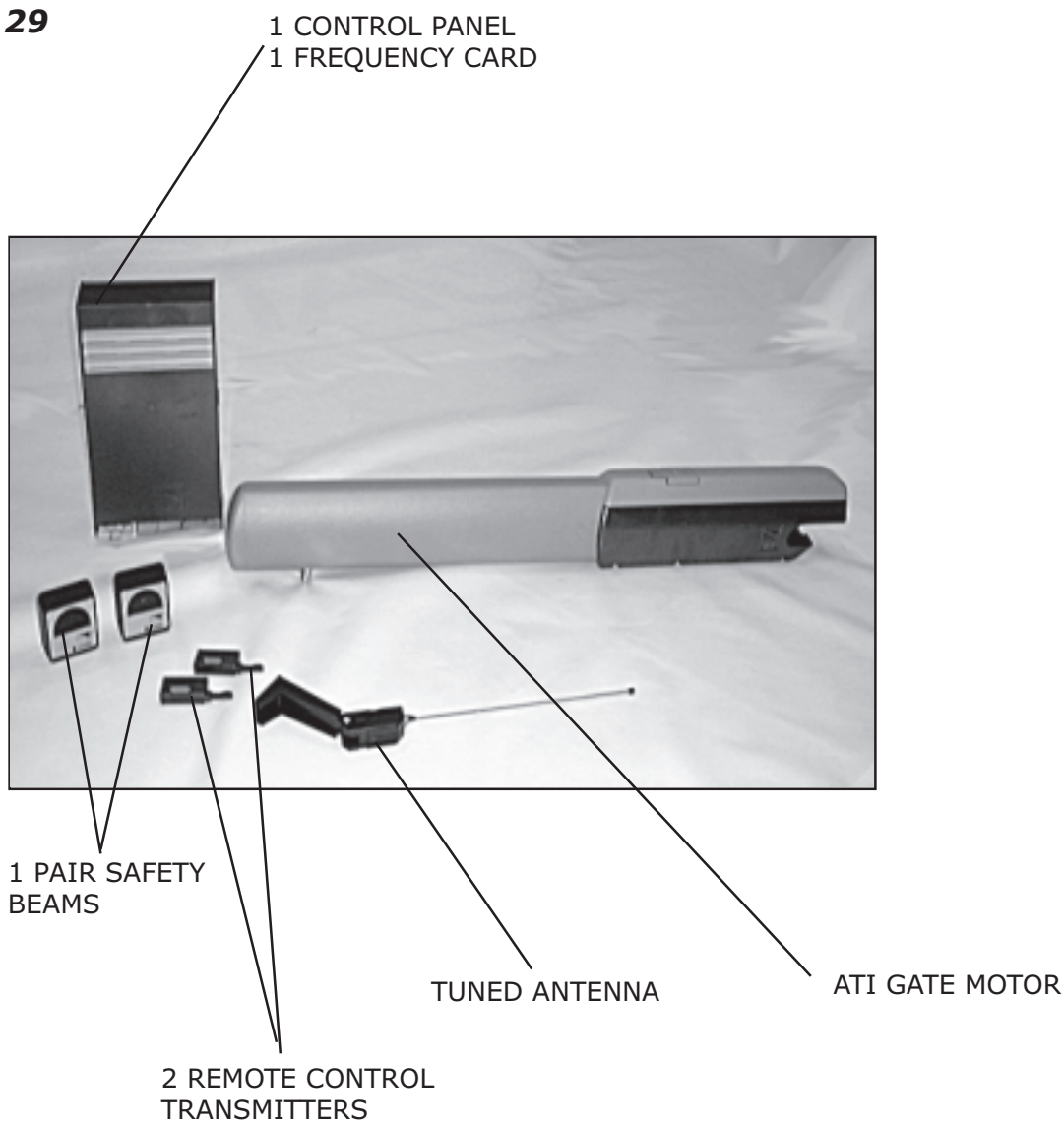

5.4 - ZA4 Wiring Diagram

Terminals 1 and 2, 2 and C1 are normally closed circuits and if they are not used they must be linked

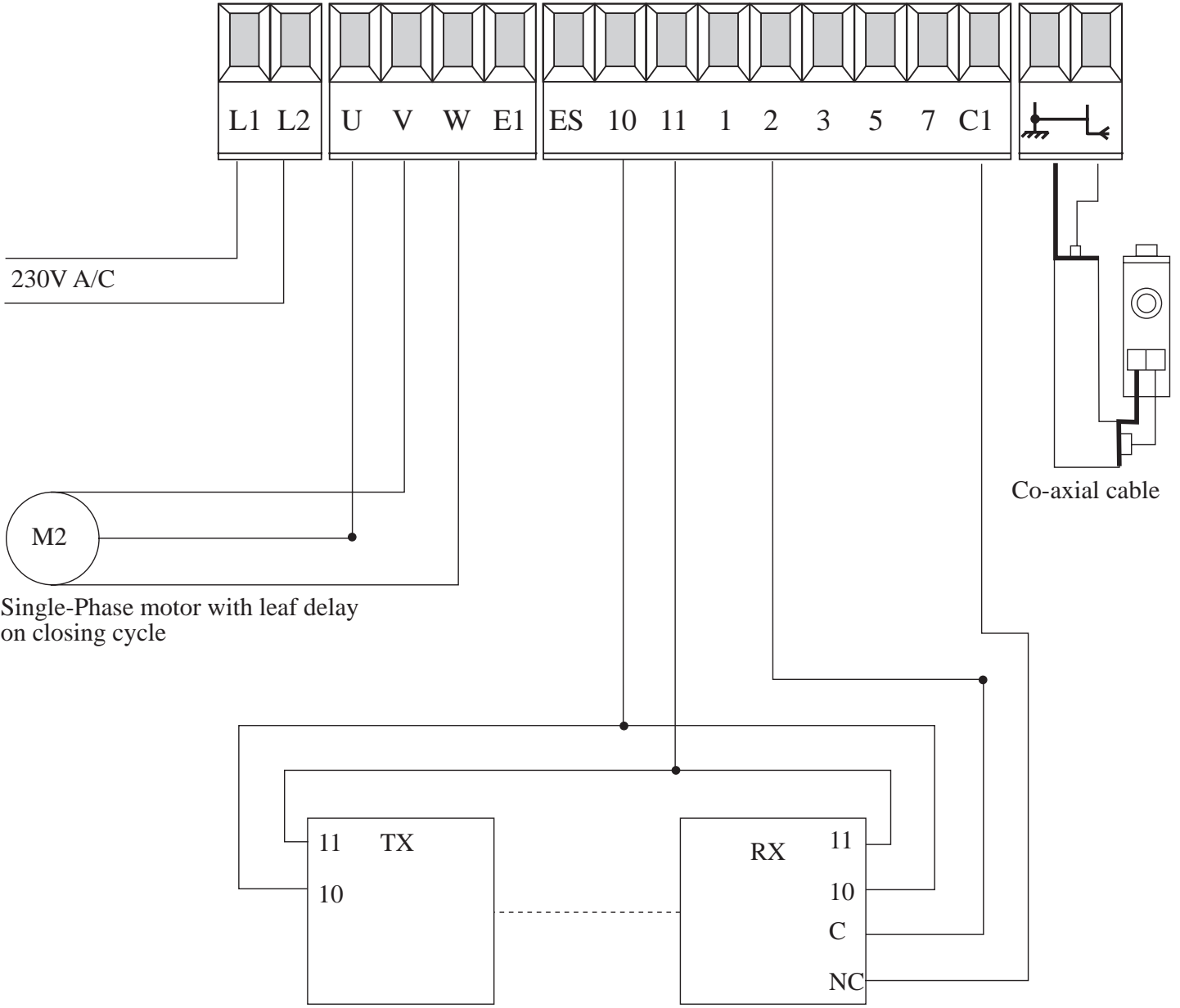

Single-Phase motor with leaf delay on closing cycle

Safety beams which are connected to obtain Re-opening During the closing cycle

5.5 - Control Panel Adjustments

Trimmer T.L. - Adjustment of operating time from a minimum of 0 seconds to a maximum of 120 seconds N.B. it is advised to let the motors run on for between 6 and 8 seconds after the last gate has fully close.

Trimmer T.C.A - Adjustment of automatic closing time from a minimum of 1 to a maximum of 120 seconds.

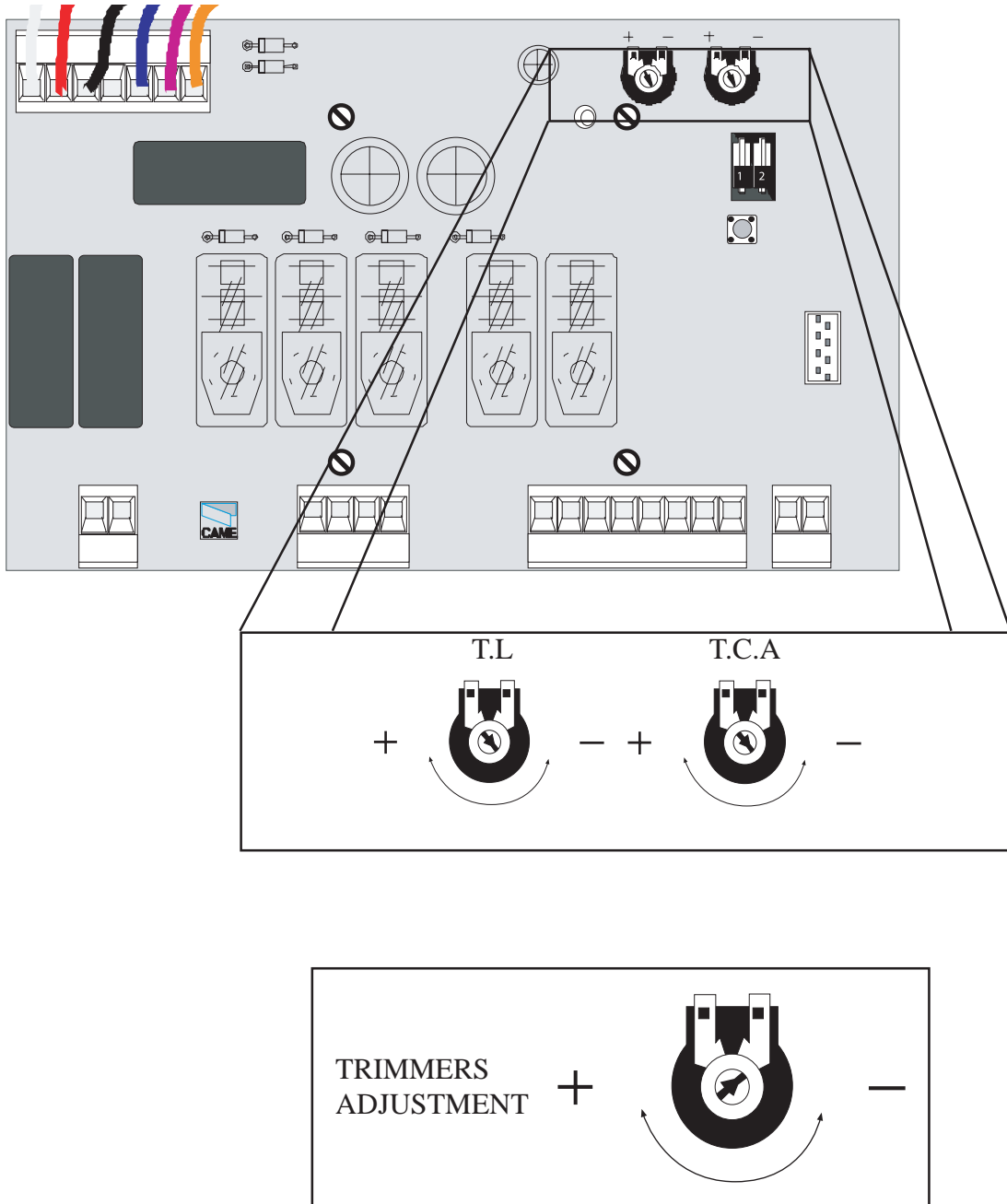
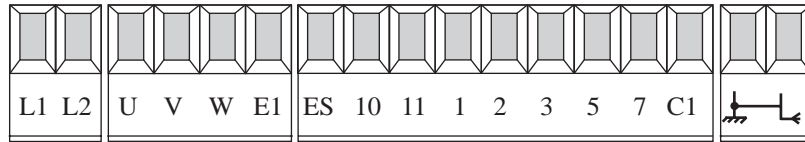

Fig 30

5.6 - Electrical Connections



L1 ————○
L2 ————○ *230V (a.c.) power input*

U ————○
W ————○
V ————○ *230V (a.c.) single-phase motor max. 600W*

W ————○
E1 ————○ *230V (a.c.) output in motion
(e.g. flashing light - max. 25W)*

11 ————○
ES ————○ *(12V - 15W max.) connection for electrically-actuated lock*

10 ————○
11 ————○ *24V (a.c.) Powering accessories (max 20W)*

10 ————○
5 ————○ *(24V-3W max.) "gate-opened" signal lamp*

1 ————○
2 ————○ *Pushbutton stop (N.C.)*

2 ————○
3 ————○ *Open button (N.O.)*

2 ————○
7 ————○ *Contact radio and/or button for control*

2 ————○
C1 ————○ *Contact (N.C.) for re-opening during the closing*

—○
—○ *Antenna connection*

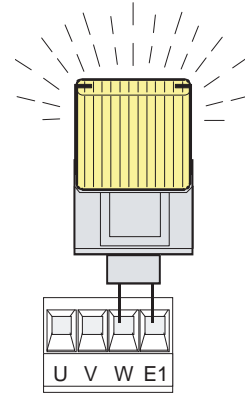

Notes

Notes

Notes

CONTACT INFORMATION

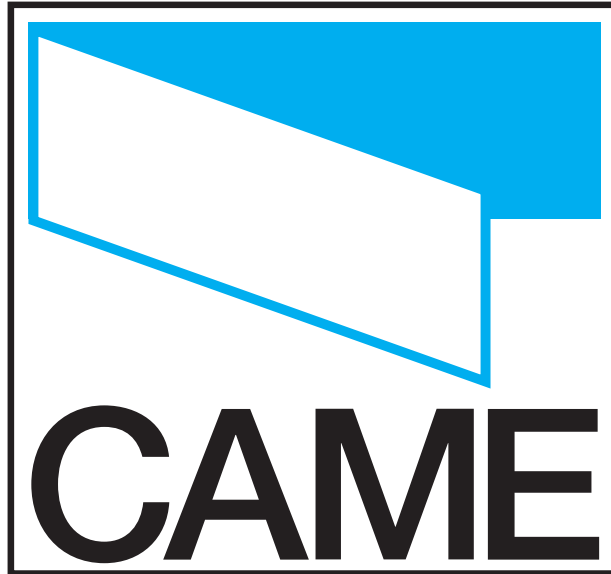

CAME UNITED KINGDOM LTD

UNIT 3

ORCHARD PARK INDUSTRIAL ESTATE
TOWN STREET, SANDIACRE, NOTTINGHAM NG10 5BP

TEL: **0115 921 0430**

FAX: **0115 921 0431**

INTERNET : www.cameuk.com

E-MAIL: enquiries@cameuk.com

THIS INSTALLATION WAS COMPLETED BY:

.....
NAME.....

ADDRESS.....

.....

.....

.....

TEL..... MOBILE.....

DATE OF INSTALLATION.....